

# CryoPen Cryosurgical System

## **OPERATOR'S MANUAL**

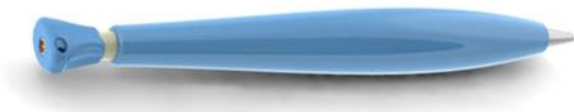

**cryosurgery at your fingertips®**



Manufactured in the U.S.A by IDM Tech, LLC for CryoPen, Inc.  
Distributed by CryoPen, Inc  
CryoPen® is a Registered Trademark of CryoPen, Inc. All Contents Copyright © All Rights Reserved  
- 1 -

Originated: 02.25.2010  
Revised: 1.17.2014  
OM-CT2-01-R8

(Minimally invasive cryosurgical unit and accessories for physician use only)

- **Caution: “Federal law restricts this device to sale by or on the order of a Physician”.**

Model number: CT-2000

**Manufactured** in the U.S.A. by IDM Tech, LLC for CryoPen, Inc.  
**Distributed by:** CryoPen, Inc.  
Corporate Office: 800 N. Shoreline Blvd. • Suite 900S • Corpus Christi TX 78401  
p: 1.888.246.3928   efax: 1.281.754.4359   www.cryopen.com

<b>CONTENTS:</b>	<b>ITEM NUMBER:</b>
CryoPen <sup>®</sup> Cooling System Assembly (1ea.)	CT-2000
Non-Sterile re-usable CryoPen <sup>®</sup> tip (1ea.) 3mm	CT2-T-5003
Non-Sterile re-usable CryoPen <sup>®</sup> tip (1ea.) 5mm	CT2-T-5005
Non-Sterile re-usable CryoPen <sup>®</sup> tip (1ea.) 7mm	CT2-T-5007
Non-Sterile re-usable CryoPen <sup>®</sup> tip (1ea.) 10mm	CT2-T-5010
Pen Core (4)	CT2-C-1000
Temperature Indicator (1ea.)	CT2-T1-1000
Reservoir Solution 500ml (1ea.)	CT2-RS-1001
Reservoir Tube- Plastic (23ml)	CT2-RS-1002
Reservoir Tube Cap (1ea.)	CT2-RS-1003
Cleaning Swabs –Single end 14”(6)	CT2-SW-1000
Transfer Pipette	CT2-PP-1000
CryoPen <sup>®</sup> Operators Packet	CT2-OP1000

**Indications For Use:**

- Intended use: Cryosurgical unit used for ablative type surgical technique
- Indications for use: Multiple organ systems, wide range of disease, viral, premalignant and malignant tissue.

**Contraindications:**

The CryoPen<sup>®</sup> is contraindicated in patients with recurrent basal cell cancers; lesions on the lower extremities (i.e. feet, ankles, lower legs) when circulation is in question, especially in patients with diabetes; lesions in the nasolabial fold or preauricular area (basal cells often are more extensive in this area); lesions in the immediate periorbital area; port-wine stains, lesions in areas in which hair loss or pigmentary changes are critical to the patient. Cryosurgery is contraindicated for use in patients with melanoma.

**Do NOT use the CryoPen<sup>®</sup> when the above listed conditions are present. The use of cryosurgical procedures in the treatment of the above listed conditions may cause serious injury to the patient.**

## **WARNINGS:**

**WARNING:** If re-usable tip gets stuck on skin, remove the Pen Core from tip by gently rotating counter clockwise to unlock it and allow to thaw.

**WARNING:** Never leave the chilling wells open. Doing so will render your unit inoperable. Always replace a cold pen core with a warm pen core that has been wiped dry and dipped in the CryoPen Reservoir Solution.

**WARNING:** Do not use the electrical charging unit near or in water. Doing so may cause electrical shock resulting in serious injury or death to the user.

**WARNING:** Do not use an extension cord. Use of extension cords may present potential fire hazards.

**WARNING:** Explosion hazard! Do not use in presence of flammable anesthetics. Unit contains 1oz. of an ethanol based proprietary solution.

**WARNING:** Ethanol is poisonous! May be fatal if swallowed and harmful if inhaled or absorbed through skin. Please refer to Material Safety Data Sheet regarding the ethanol based reservoir solution.

**WARNING:** The CryoPen<sup>®</sup> Pen Cores are extremely cold. Accidental contact with core may result in frostbite. Touch only the blue plastic handle when core is at cryogenic temperatures.

**WARNING:** Clean CryoPen<sup>®</sup> Pen Cores by wiping down with soap and water or with standard solutions such as CryoPen's Reservoir Solution or isopropyl alcohol. Clean only when they have reached room temperature. Do not submerge the Pen Cores in water or any cleaning solution. Doing so will render them inoperable.

**WARNING:** Do not use the CryoPen<sup>®</sup> Pen Core without a sterile or disinfected tip. Use of unprocessed tip will expose your patients to non-sterile conditions and may cause cross patient contamination. Pen Core at cryogenic temperatures could also become stuck on patient's skin thereby causing injury to the patient.

## **PRECAUTIONS:**

- **CAUTION:** This device should be used with caution on patients with diabetes, peripheral vascular disease or cold intolerance problems.
- **CAUTION:** Use of CryoPen<sup>®</sup> on lesions with hair, may cause patient to lose hair.
- **CAUTION:** Use of CryoPen<sup>®</sup> on lesions in areas where pigment is critical to patient, patient should be made aware that change in pigment may result.
- **CAUTION:** Federal Law restricts this device to sale, distribution and use by or on the order of a physician.
- **CAUTION:** Reservoir solution contains alcohol (ethanol) Avoid skin contact with the reservoir solution on persons taking the medication ANTABUSE<sup>®</sup>.
- **CAUTION:** Handle the copper pen cores with great care. Dropped pen cores will be damaged and may become trapped in the pen tips.
- **CAUTION:** Cold pen cores should be placed in a tip or defrost wells immediately to avoid damage.

## POWER OUTAGE

- **Step one:** Turn unit off, UNPLUG FROM WALL and allow to defrost.
- **Step two:** After unit has reached room temperature, approximately 8 hours, unplug the power supply from unit and remove Pen Cores from the chilling wells.
- **Step three:** Using the 14" swab that is provided, remove all reservoir solution and water from the chilling wells. Wells should be completely dry.
- **Step four:** Remove reservoir tube from the unit, discard old solution and refill to the maximum line (3 pipettes).
- **Step five:** Dry all Pen Cores with cotton towel. Using the supplied plastic Pipette, fill each chilling well with reservoir solution (one Pipette full per well). Place 1 pen core into each of the wells. Place remaining two pen cores in the holding wells.
- **Step six:** Plug the power supply into the unit and turn unit on (Located on left side of unit). Green light will illuminate on front of unit. System will be ready for use in approximately 120 minutes. Test Pen Cores for readiness using the temperature indicator.

**The above steps should be followed each time you have a power outage.**

## POWER SURGE

- **Step one:** Turn unit off and UNPLUG FROM WALL outlet/surge protector, wait 3-5 minutes then re-plug electrical cord into wall outlet/line surge protector and turn system back on. This will allow your system to reset.
- **Step two:** If unit does not chill properly after this process, turn unit off and follow the steps for a Power Outage and/or call Technical Support at 1.877.246.3955.

**Note: We recommend using a line surge protector to protect this system and your investment.**

## **DESCRIPTION:**

The CryoPen<sup>®</sup> system provides a means of freezing tissue without the use of cryogenic gases or liquids. The system consists of four pen cores, a refrigeration unit, re-usable tips in (4) four sizes and a temperature indicator. When used properly, the system will deliver effective temperatures for tissue ablation.

The CryoPen<sup>®</sup> Cooling System: The unit is a refrigeration component that operates on AC 110-240 volts obtained from conventional convenience outlets. It is used to lower the temperature of the CryoPen<sup>®</sup> pen cores to temperatures of -105°C to -110°C.

The CryoPen<sup>®</sup> Pen Cores: Consists of a heat sink that has been shaped at one end to form a treatment surface that is inserted into the pen tips. (4 sizes: 3mm, 5mm, 7mm and 10mm) A connection for proper temperature indication is on the top of the pen core. Readiness of the Pen Cores should be checked using the temperature indicator for readiness before each use.

The CryoPen<sup>®</sup> Re-usable Tips: Tips consist of resilient medical grade plastic that contains an aluminum tip. When surgery is complete, remove the pen core from the tip. Re-sterilize tips in-between patients. Failure to do this will result in non-sterile conditions and may cause cross patient contamination.

### Temperature Indicator: Indicates readiness of CryoPen<sup>®</sup> Pen Cores

To initialize, please ensure that the connector on the bottom of the indicator is fully seated on the pen core. If the status LED fails to light, please try again.

When the temperature indicator is plugged into the CryoPen<sup>®</sup> Pen Core please allow between one/two seconds for the indicator to register one of the following:

1. Solid red light indicates the CryoPen<sup>®</sup> is not cold enough for a procedure;
2. Blinking green light indicates that the CryoPen<sup>®</sup> has reached sufficient temperature to allow for a two minute freeze time;
3. Solid green light indicates that the CryoPen<sup>®</sup> has reached optimal temperature to ensure a freeze time of three minutes;
4. Blinking red /green lights together, indicates the CryoPen<sup>®</sup> is too cold to perform a procedure. Please contact CryoPen<sup>®</sup> immediately in such an instance.

**The temperature indicator's status LED will stay lit for approximately three to five seconds while connected to a Pen Core.**

**Note: The temperature indicator also turns solid red when connected to a pen core at ambient conditions. If no light is visible when the indicator is attached to a pen core, contact CryoPen, Inc. at 1-877-246-3955**

**Model: CT-2000**

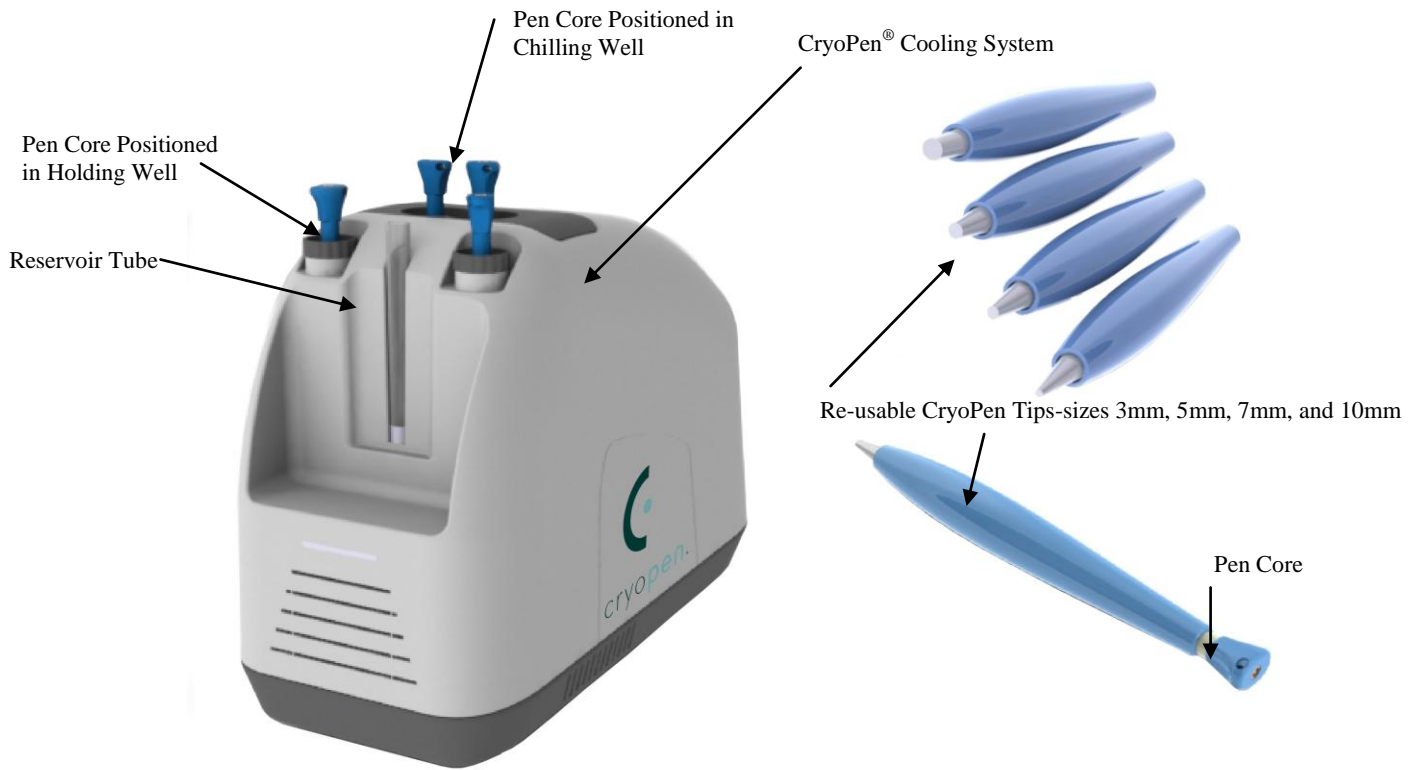

**Temperature Indicator: Indicates readiness of CryoPen® Pen Cores**



## INSTRUCTIONS FOR MODEL CT-2000:

**WARNING: SET-UP IS SIMPLE BUT YOU WILL WANT TO CAREFULLY REVIEW THE OPERATOR'S MANUAL BEFOREHAND.**

1. Read Operator's Manual
2. Unpack contents of shipment: Unit containing (4) Pen Cores, Power Supply w/electrical cord, (1) Temperature Indicator, (1) 500ml Reservoir Bottle, 4 sizes of non-sterile tips (1 of each size), (1) Reservoir Tube (1) Reservoir Cap (1) pack of swabs and (1) CryoPen Towel.
3. Locate unit by the nearest 110-240 volt outlet. Plug power supply into the unit and electrical cord into outlet (See Note Below). Fan will automatically come on and red light will illuminate on front of unit. If green light on front of unit is illuminated at this time, place the power switch to the off position. **Unit should not be turned on yet.** Unit must be placed at least 1½ inches away from the wall/counter backsplash to prevent overheating.  
**Note: We recommend the use of a line surge protector to protect the unit and your investment**  
**WARNING: Do not use an extension cord. Use of extension cords may present potential fire hazard.**
4. Fill Reservoir Tube to the line using the supplied Reservoir Solution. Do Not Overfill! Store remaining solution in a cool dry place. **Note:** The use of any other solution other than that obtained from CryoPen, Inc. will void your warranty. After the Reservoir tube is filled, remove the (2) pen cores from the Chilling Wells located on top of unit. Using the supplied transfer pipette, fill each well with (1) one pipette full of reservoir solution from the reservoir tube or reservoir bottle.
5. Insert 2 CryoPen® Pen Cores fully into the chilling wells. **Pen Cores should always be dipped into Reservoir Solution before inserting into chilling wells after initial set-up.** Chilling wells reach -105°C to -110°C. Make sure pen cores are properly seated in chilling wells. Failure to do this will result in pen cores not reaching optimal temperature. If a Pen Core is not replaced into a chilling well, freezing of the well will occur and unit defrosting will be necessary.  
**Note: Never leave chilling wells open.**
6. Turn on power switch at left side panel of unit. When unit is turned on a green light will illuminate on front of unit. The unit will be operational in approximately 120 minutes. Unit is designed to remain on unless a problem is encountered or service is needed.
7. After unit has reached the operating temperature, approximately 120 minutes, test the Pen Core temperature readiness using the temperature indicator.

**Note:** After initial set-up allow warm CryoPen® Pen Cores to chill in chilling wells for approximately 10-20 minutes before re-use. Always check readiness by using the temperature indicator. **Pen Cores should always be dipped into Reservoir Solution before inserting into chilling wells.**

8. To perform cryosurgery
  - A.) Check temperature readiness of pen core from chilling wells using the Temperature Indicator.
  - B.) Select appropriate re-usable tip (sizes 3mm, 5mm, 7mm, and 10mm)
  - C.) From Holding Wells (located on front of unit) remove warm pen core, wipe dry, dip pen into reservoir tube. **DIP NOTE:** Pen Cores should always be wiped dry before dipping into reservoir tube. Failure to wipe dry, can contaminate solution and may cause failure of unit.
  - D.) Remove Pen Core from chilling well. Replace with dipped pen core.
  - E.) Holding the selected tip in its upright position, lower the pen core aligning the two small locking pins with the slots in the tip. Gently rotate clock wise to lock in place. **Caution:** Do not use excessive force. **Caution:** Aluminum tip is now at cryogenic temperatures. Begin procedure immediately. Do Not Touch Tip.

F.) After procedure, remove pen core from tip and place in holding well for defrosting. After defrosting, proceed to clean and reprocess tip according to Step 9 below.

G.) Reservoir Tube should be checked daily and filled as needed. (Fill to maximum line.)

H.) Pen Cores should be rotated at the end of each day. Rotate from holding wells to chilling wells.  
(Each holding pen core should be wiped dry and dipped before placing it into a chilling well)

I.) If CryoPen® Pen Cores become stuck in chilling wells turn unit OFF and allow unit to defrost. (approximately 8 hours) Wells and pen cores should be wiped dry using the supplied cotton towel and swabs. (See separate Instructions for Maintenance and Power Outage).

J.) The system is designed to remain on. Turning the unit on and off will cause the pen cores in the chilling wells to defrost resulting in water contamination of the reservoir solution. In this instance, chilling wells have to be cleaned and a return to initial setup procedures will be necessary. Unit should be placed in a well-ventilated and clean environment for maximum efficiency.

**Warning:** Pen Cores are extremely cold, accidental contact with skin may cause frostbite.

## 9. Instructions for Cleaning & Reprocessing CryoPen Reusable and Sterilizable tips: (for General/Dermatology use)

A. Thoroughly clean all surfaces of the CryoPen tip to remove blood and particles.

- 1.) Wear heavy-duty rubber gloves, a plastic apron, eye protection, and mask during cleaning as needed.
- 2.) Soak the instruments in normal tap water containing a detergent such as Enzol®, according to manufacturer's instructions.
- 3.) Scrub instruments as necessary to completely remove all foreign material using a soft brush or old toothbrush, detergent, and water. Hold items under the surface of the water while scrubbing and cleaning to avoid splashing. Do not attempt to disassemble the tip. Be sure to brush where organic material can collect and stick.
- 4.) Flush through the inside of the tip.
- 5.) Rinse items thoroughly with clean water to remove all detergent. Any detergent left on the items can reduce the effectiveness of further processing.
- 6.) Inspect items to confirm that they are clean and free of visible debris.
- 7.) Allow items to air dry or dry them with a clean towel if chemical disinfection is going to be used. This is to avoid diluting the chemical solutions used after cleaning. Items that will be processed in an autoclave do not need to be dried.

B-1. If tip has come into contact with broken skin or a mucous membrane perform one of the following (see Table 1):

- 1.) Place in cold soak high level disinfectant/sterilant fluid (e.g. glutaraldehyde based solutions) and follow manufacturer's instructions.
- 2.) Steam sterilize (autoclave) by gravity with a cycle temperature of 270 degrees Fahrenheit @ 20-30psi for 15 minutes. Allow 20 minutes to dry.



B-2. If tip has come into contact with intact skin perform intermediate (low or mid-level) disinfection according to manufacturer's instructions (see Table 1)

C-1. Upon removal from chemical disinfectants or sterilants, all surfaces must be wiped with CryoPen Reservoir Solution (or an alcohol pad) and allowed to air dry completely.

C-2. Upon removal from autoclave, please allow tip to dry completely

D. The CryoPen tip is now ready for reuse.

Note: Before reusing a CryoPen® Tip it should be thoroughly and completely dry. If placed on a Pen Core while wet inside or out, it will become stuck, and thawing will be necessary to remove it.

**Table 1: Recommendations on Reprocessing of Reusable Medical Devices (subsequent to cleaning)**

<i>CryoPen Tip Usage (i.e. where cryosurgery takes place)</i>	<i>Low or Mid-level Disinfection</i>	<i>High-Level Disinfection or Sterilization</i>
Intact Skin or no likelihood of transmissible bacteria, organisms, etc.	<b>X</b>	
Broken Skin & Mucosal Membrane		<b>X</b>

**Expected Ablation and Transition Zones For Dermatology/General Cryosurgery**

a.) Expected Cryoablation zones for 5mm, 7mm, and 10mm Tip sizes (data derived from bench testing on chicken meat without skin)

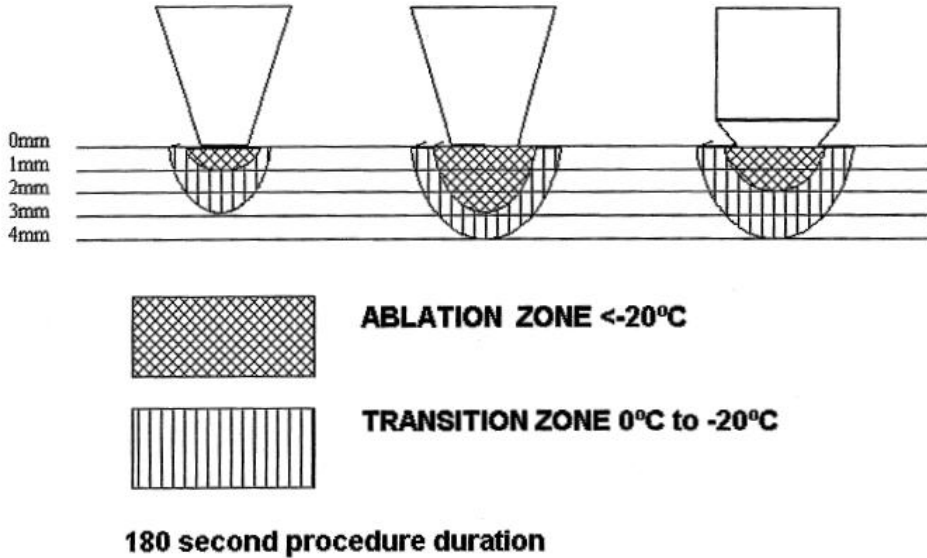

b.) Expected Cryoablation zone for 3mm Tip, 180 seconds of contact (data derived from bench testing on ballistic gelatin)

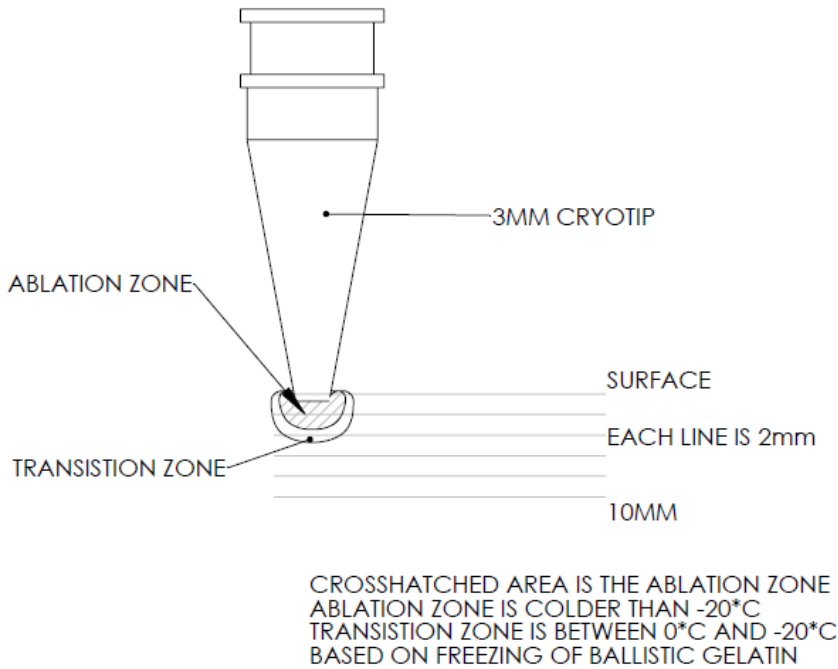

## **CLEANING:**

**The CryoPen® Cooling System:** The main unit, except for the CryoPen® chilling wells, may be cleaned and disinfected as needed using isopropyl alcohol or Reservoir Solution. CryoPen® chilling wells may be cleaned periodically as dust and debris may collect in them to the point of making poor contact with the Pen Cores. To clean these chilling wells, use the provided swabs. Use a blotting and circular motion to clean out chilling wells. Never place your fingers into the chilling wells, due to the extreme cold. Do not submerge the unit into water; doing so will present an electrical hazard and destroy the unit. It is important **not to** leave chilling wells open for an extended period of time. Swabbing the wells can be completed quickly when rotating pens.

**The CryoPen® Pen Cores:** may be wiped cleaned with soap and water when the Pen Cores are at room temperature (70-75° degrees Fahrenheit) or cleaned (with such standard solutions as isopropyl alcohol or CryoPen's Reservoir Solution) as needed. Do not submerge pen cores into liquid of any kind. Doing so will render them inoperable. CryoPen® Pen Cores should never be used for a procedure without the appropriate tip in place.

**Reservoir Solution:** Should be filled to the maximum line at all times and should be completely changed weekly. Swab and dry out tube completely before refilling. Refill with reservoir solution from 500ml. bottle. **Note:** The use of any other solution other than that obtained from CryoPen, Inc. will void warranty.

## **DAILY MAINTENANCE:**

- Daily maintenance can be done while the unit is on.
- Rotate pen cores from the holding wells to the chilling wells at the end of each day. During weekends, it is not necessary to rotate pen cores. (Make sure all pen cores from holding wells are wiped dry and dipped before placing into chilling wells.)
- Reservoir tube should be checked daily and filled as needed to the maximum line.
- Reservoir solution level in tube should be kept at the maximum level at all times. Remove Reservoir Cap if used and discard old solution at the end of each week. Dry tube thoroughly using the supplied swab, replace tube into unit. Refill the tube with supplied Reservoir Solution stored in the 500ml bottle. Open cap and dispense into reservoir tube.
- Reorder 500ml Reservoir Solution as needed.
- Clean and disinfect system as needed by wiping down with standard isopropyl alcohol or Reservoir Solution.
- Make sure unit and surrounding area is kept free from dust.
- Periodically remove holding wells from unit and clean with warm soapy water and air dry.

## **QUARTERLY MAINTENANCE:**

- The unit must be turned off before quarterly maintenance can be performed. We recommend waiting 8 hours for unit to reach room temperature.
- Thoroughly dry wells using the supplied swabs and wipe pen cores dry.
- Then, follow the initial set-up procedure located in the Operator's Manual.

**Note: If the unit is not in use for more than two days (i.e. extended weekends, holidays, or vacations), it should be turned off. If the unit remains on and the pen cores are not rotated, the pen cores will seize in the chilling wells. In this instance, initial set-up procedures must be followed. Also, when the unit remains off for several consecutive days, initial set-up procedures should be followed to properly restart the unit.**

**There are no user-serviceable parts contained in the CryoPen® Cryosurgical System. Only CryoPen, Inc. designated personnel are authorized to perform repairs on the CryoPen® Cryosurgical System or accessories. Use of unauthorized personnel will void any and all manufacturer's warranties.**

**FOR GENERAL INFORMATION AND TO ORDER ADDITIONAL SUPPLIES CONTACT  
CRYOPEN, INC.:**

**Call: 1-877-246-3955**

**CryoPen, Inc.**

**Corporate Office:** 800 N. Shoreline Blvd. • Suite 900S • Corpus Christi TX 78401

Toll Free: 1-888-246-3928

E-Fax: 1-281-754-4359

**TECHNICAL SUPPORT AND/OR SERVICE/REPAIR DEPARTMENT:**

**Call: 1-877-246-3955**

If your CryoPen<sup>®</sup> Cryosurgical System becomes inoperable or any device related incidents or problems occur, which are suspected to represent a safety issue should be reported immediately to CryoPen, Inc. at 1-877-246-3955

Our staff will be happy to assist you.

Protected by U.S. Patents 6430956, 6629417, UK Patent GB2392230; other U.S. and Foreign patent(s) pending.

CryoPen is a registered trademark of CryoPen, Inc.

© Copyright ALL RIGHTS RESERVED

Manufactured in the U.S.A by IDM Tech, LLC for CryoPen, Inc.

Distributed by CryoPen, Inc

CryoPen<sup>®</sup> is a Registered Trademark of CryoPen, Inc. All Contents Copyright © All Rights Reserved

- 13 -

Originated: 02.25.2010

Revised: 1.17.2014

OM-CT2-01-R8



## WARRANTY

The only warranty granted herein is an expressed, limited warranty as written, as there are no implied warranties.

CryoPen, Inc. warrants, to the extent and subject to the limitations described in this warranty, the **CryoPen® Cryosurgical System** sold hereunder to be free from defects in material and workmanship if properly installed, serviced, and operated under normal conditions according to the CryoPen® Cryosurgical System Operators Manual.

This is a limited warranty and CryoPen, Inc. agrees only to correct or replace, at its option, any CryoPen® system that shall be returned to CryoPen, Inc. Transportation of the unit will be prepaid by the original owner, after being placed into service by the original owner, provided that CryoPen, Inc. is satisfied that the equipment was originally defective in either workmanship or materials. This warranty is not transferable without the expressed written consent of CryoPen, Inc. and there shall be no obligation by seller to repair or replace, in whole or in part, either the entire unit, and/or any component part.

Normal “wear and tear” is not warranted. If any unit is rendered unusable because of misuse, negligence, or accident, or if any unit has been altered or serviced by someone other than CryoPen, Inc. then this warranty shall be voided.

This warranty is not applicable to components manufactured by others. If components of the unit have been manufactured by someone other than CryoPen, Inc. then that manufacturer’s warranty shall apply to those components manufactured by a third party. If any part of the unit is serviced by persons, firms, or agents not authorized by CryoPen, Inc., then this warranty is void.

This warranty is in lieu of all other warranties, expressed or implied, including warranties of merchantability and fitness for a particular purpose, and no person, agent or dealer is authorized to give any further warranties on behalf of CryoPen, Inc. unless such warranty is in writing and signed by an officer of CryoPen, Inc.

This limited warranty is in effect for one year from the date of the original purchase and is non-transferable and only valid for original purchaser.